



GT14L 'PowerTrap' Mechanical Pump w/ Steam Trap

Features

Pump/Trap with built-in steam trap for a wide range of applications: drainage of medium capacity heat exchangers, flash steam recovery systems and reservoirs, often operating under vacuum conditions.

1. Handles high-temperature condensate without cavitation.
2. No electric power or additional level controls required, hence INTRINSICALLY SAFE.
3. Pump will operate with a low filling head (min. 300 mm).
4. Easy, inline access to internal parts simplifies cleaning and reduces maintenance costs.
5. High-quality stainless steel internals and hardened working surfaces ensure reliability.
6. Compact design permits installation in a limited space.



Specifications

Model		GT14L	
Body Material		Cast Iron	Cast Steel
Connection	Pumped Medium Inlet & Outlet	Flanged*	
	Motive Medium & Pump Exhaust	Screwed	
Size	Pumped Medium: Inlet x Outlet	DN 40 x DN 25	
	Motive Medium Inlet	½"	
	Pump Exhaust Outlet	½"	
Maximum Operating Pressure (barg)	PMO	13	14
Maximum Operating Temperature (°C)	TMO	200	220
Motive Medium Pressure Range (barg)		0.3 – 13	0.3 – 14
Maximum Allowable Back Pressure		0.5 bar less than motive medium pressure used	
Volume of Each Discharge Cycle (ℓ)		Approx. 8.0	
Motive Medium**		Saturated Steam	
Pumped Medium***		Steam Condensate	

* For details of flange connection, see picture at bottom right. ** Do not use with toxic, flammable or otherwise hazardous fluids. 1 bar = 0.1 MPa
 *** Do not use for fluids with specific gravities under 0.85 or over 1, or for toxic, flammable or otherwise hazardous fluids.

PRESSURE SHELL DESIGN CONDITIONS (NOT OPERATING CONDITIONS):

Maximum Allowable Pressure (barg) PMA: 13 (Cast Iron), 21 (Cast Steel)
 Maximum Allowable Temperature (°C) TMA: 200 (Cast Iron), 260 (Cast Steel)

CAUTION To avoid abnormal operation, accidents or serious injury, DO NOT use this product outside of the specification range. Local regulations may restrict the use of this product to below the conditions quoted.

No.	Description	Material	DIN*	ASTM/AISI*
①	Body	Cast Iron FC250	0.6025	A126 Cl.B
		Cast Steel** A216 Gr.WCB	1.0619	—
②	Cover	Cast Iron FC250	0.6025	A126 Cl.B
		Cast Steel** A216 Gr.WCB	1.0619	—
③	Cover Gasket	Graphite Compound	—	—
④	Float	Stainless Steel SUS316L	1.4404	AISI316L
⑤	Snap-action Unit	Stainless Steel	—	—
⑥	Motive Medium Intake Valve Unit	Inlet Valve	1.4125	AISI440C
		Valve Seat	1.4028	AISI420F
⑦	Exhaust Valve Unit	Exhaust Valve	1.4125	AISI440C
		Valve Seat	1.4028	AISI420F
⑧	Steam Trap Unit	Stainless Steel	—	—
⑨	Inlet Check Valve CKF5M	Stainless Steel SUS304	1.4301	AISI304
⑩	Outlet Check Valve CKF3M	Cast Stainless Steel A351 Gr.CF8	1.4312	—

* Equivalent materials ** Option: Cast Stainless Steel

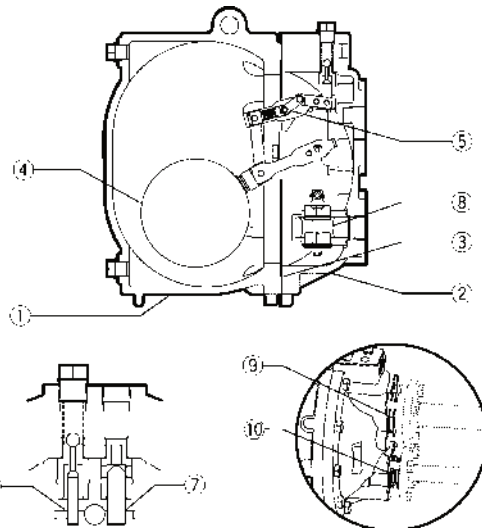

Dimensions

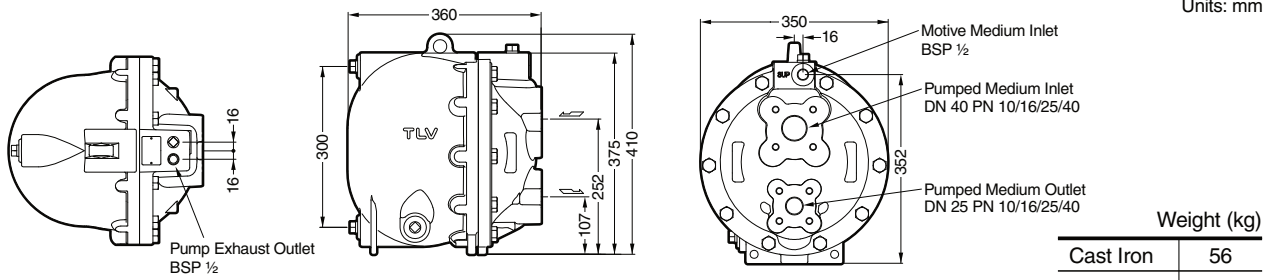

Note: All Plug Holes BSP 1/2

Discharge Capacity

Connection:	Flanged
Inlet size:	DN 40
Outlet size:	DN 25
Check Valve:	
Inlet (CKF5M):	DN 40
Outlet (CKF3M):	DN 25
Filling Head:	630 mm

• Correction Factor

For GT14L installed with filling head other than 630 mm (minimum filling head: 300 mm)

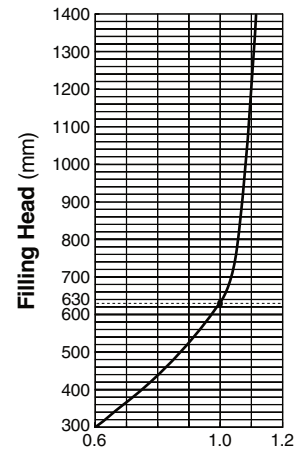
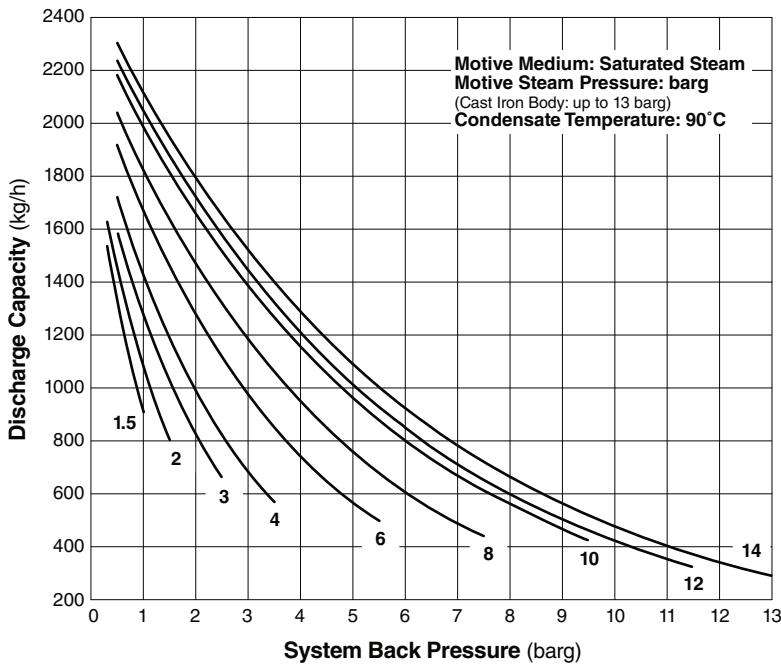

• Illustration of Filling Head and Pressures

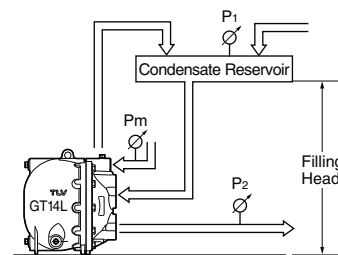

NOTE:

- A check valve must be installed at both the pumped medium inlet and outlet. To achieve the above capacities with the standard GT14L configuration, TLV check valves CKF5M for inlet and CKF3M for outlet must be used.
- Motive steam pressure minus back pressure must be greater than 0.5 barg.
- A strainer must be installed at the motive medium and pumped medium inlets.

- The discharge capacity is determined by the motive medium, motive medium pressure (P_m) and back pressure (P₂).

Make sure that:

$$\text{Discharge Capacity} \times \text{Correction Factor} > \text{Required Flow Rate}$$

Size of Reservoir

The reservoir must have a capacity sufficient to store the condensate produced during the **PowerTrap** operation and discharge.

Size of Reservoir (flash steam is not involved)

Amount of Condensate (kg/h)	Reservoir Diameter (mm) and Length (m)						
	40	50	80	100	150	200	250
300 or less	1.2 m	0.7					
400	1.5	1.0					
500	2.0	1.2	0.5				
600		1.5	0.6				
800		2.0	0.8	0.5			
1000			1.0	0.7			
1500			1.5	1.0			
2000			2.0	1.3	0.6		
3000				2.0	0.9	0.5	
4000					1.2	0.7	
5000					1.4	0.8	0.5
6000					1.7	1.0	0.6
7000					2.0	1.2	0.7
8000						1.3	0.8
9000						1.5	0.9
10000						1.7	1.0

Reservoir length can be reduced by 50% when the motive medium pressure (P_m) divided by back pressure (P_2) equals 2 or greater (when $P_m \div P_2 \geq 2$).

Steam Consumption (Motive Medium)

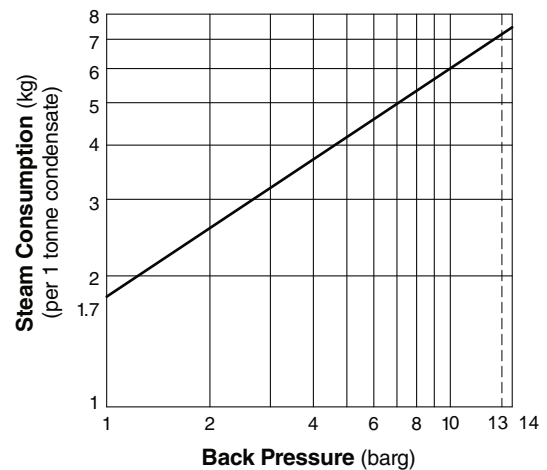

GT14L Steam Trap Discharge Capacity

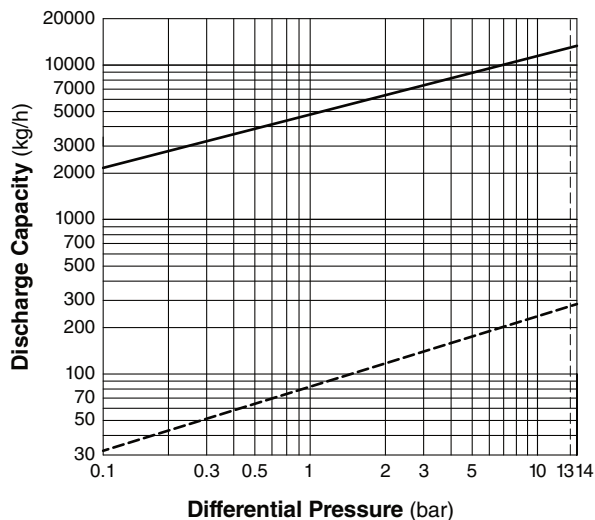

- : Capacity of GT14L as a steam trap ($P_1 > P_2$). Instantaneous condensate loads above the rated trap capacity will cause the pump to cycle and therefore reduce the discharge capacity.
- - - : Minimum amount of condensate required to prevent steam leakage.

1. Capacities are based on continuous discharge of condensate 6 °C below steam temperature.
2. Differential pressure is the difference between inlet and outlet pressure of the trap.



CAUTION

DO NOT use this product under conditions that exceed maximum differential pressure, as condensate backup will occur!