



GP10L 'PowerTrap' Mechanical Pump

Features

Pump for a wide range of applications. Ideal for low flow condensate removal from vented receivers situated at low levels.

1. Handles high-temperature condensate without cavitation.
2. No electric power or additional level controls required, hence **INTRINSICALLY SAFE**.
3. Pump will operate with a low filling head (min. 300 mm).
4. Easy, inline access to internal parts simplifies cleaning and reduces maintenance costs.
5. High-quality stainless steel internals and hardened working surfaces ensure reliability.
6. Compact design permits installation in a limited space.
7. Cycle Counter installable as option.

Pressure Equipment Directive (PED)

Classification according to PED 2014/68/EU, fluid group 2

Size	Category	CE marking
DN 25, DN 40	I	With CE marking and Declaration of Conformity



Specifications

Model		GP10L	
Connection	Pumped Medium Inlet & Outlet	Screwed and Flanged*	Screwed
	Motive Medium & Pump Exhaust	Screwed	
Size	Pumped Medium: Inlet x Outlet	1"/ DN 25 x 1"/ DN 25	1½" x 1"
	Motive Medium Inlet	½"	
	Pump Exhaust Outlet	½"	
Maximum Operating Pressure (barg)	PMO	10.5	
Maximum Operating Temperature (°C)	TMO	185	
Motive Medium Pressure Range (barg)		0.3 to 10.5	
Maximum Allowable Back Pressure		0.5 bar less than motive medium pressure used	
Volume of Each Discharge Cycle (litre)		approximately 6	
Motive Medium**		Saturated Steam, Compressed Air, Nitrogen	
Pumped Medium***		Steam Condensate, Water	
Optional Specifications for Hazardous Locations		ATEX: Ⓜ II2G Ex h IIC T3 Gb	

* For details of flange connection, see picture at bottom right ** Do not use with toxic, flammable or otherwise hazardous fluids.

1 bar = 0.1 MPa

*** Do not use for fluids with specific gravities under 0.85 or over 1, or for toxic, flammable or otherwise hazardous fluids.

PRESSURE SHELL DESIGN CONDITIONS (NOT OPERATING CONDITIONS):

Maximum Allowable Pressure (barg) PMA: 13 (Cast Iron), 21 (Cast Steel), 16 (Cast Stainless Steel)

Maximum Allowable Temperature (°C) TMA: 200 (Cast Iron), 220 (Cast Steel, Cast Stainless Steel)



To avoid abnormal operation, accidents or serious injury, DO NOT use this product outside of the specification range. Local regulations may restrict the use of this product to below the conditions quoted.

No.	Description	Material	DIN*	ASTM/AISI*		
①	Body	Cast Iron FC250	0.6025	A126 Cl.B		
		Cast Steel A216 Gr.WCB**	1.0619	—		
		Cast Stainless Steel A351 Gr.CF8	1.4312	—		
②	Cover	Cast Iron FC250	0.6025	A126 Cl.B		
		Cast Steel A216 Gr.WCB**	1.0619	—		
		Cast Stainless Steel A351 Gr.CF8	1.4312	—		
③	Cover Gasket	Graphite Compound	—	—		
④	Float	Stainless Steel SUS316L	1.4404	AISI316L		
⑤	Snap-action Unit	Stainless Steel	—	—		
⑥	Motive Medium Intake Valve Unit	Intake Valve	Stainless Steel SUS440C	1.4125	AISI440C	
		Valve Seat	Stainless Steel SUS420F	1.4028	AISI420F	
⑦	Exhaust Valve Unit	Exhaust Valve	Stainless Steel SUS440C	1.4125	AISI440C	
		Valve Seat	Stainless Steel SUS420F	1.4028	AISI420F	
⑧	Inlet Check Valve	Screwed	CK3MG**	Cast Stainless Steel A351 Gr.CF8	1.4312	—
		Flanged	CKF5M	Stainless Steel SUS304	1.4301	AISI304
⑨	Outlet Check Valve	Screwed	CK3MG**	Cast Stainless Steel A351 Gr.CF8	1.4312	—
		Flanged	CKF3M	Cast Stainless Steel A351 Gr.CF8	1.4312	—

* Equivalent materials ** Not shown

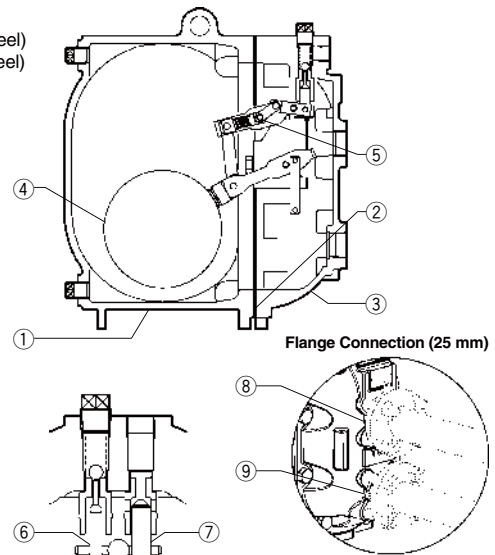

Discharge Capacity

A

Connection:	Screwed
Inlet size:	1"
Outlet size:	1"
Check Valve:	CK3MG
Inlet:	1"
Outlet:	1"
Filling Head:	630 mm

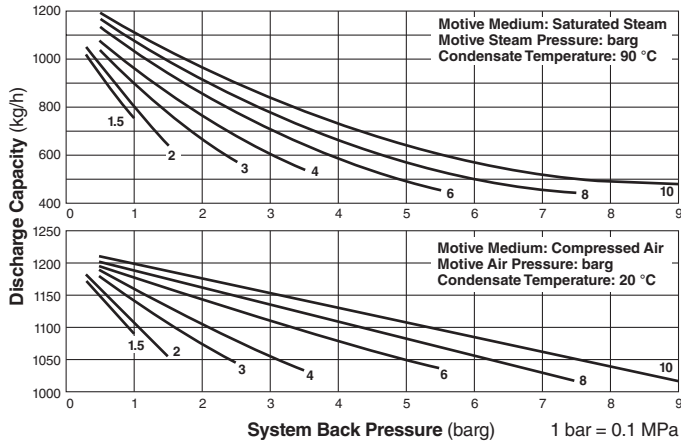

● **CORRECTION FACTOR**

For discharge capacity graph **A** installed with filling head other than 630 mm (minimum filling head: 450 mm)

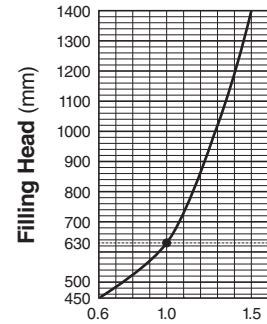

B

Connection:	Screwed
Inlet size:	1½"
Outlet size:	1"
Check Valve:	CK3MG
Inlet:	1½"
Outlet:	1"
Filling Head:	630 mm

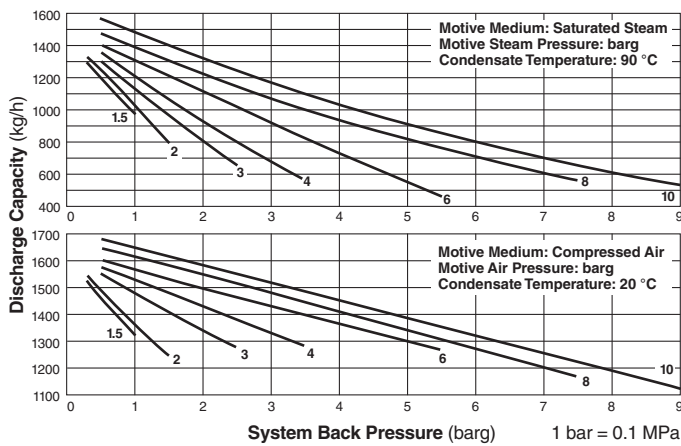

● **CORRECTION FACTOR**

For discharge capacity graph **B** with filling head other than 630 mm (minimum filling head: 450 mm)

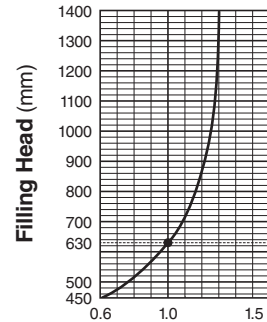

C

Connection:	Flanged
Inlet size:	DN 25
Outlet size:	DN 25
Check Valve:	
Inlet (CKF5M):	DN 25
Outlet (CKF3M):	DN 25
Filling Head:	630 mm

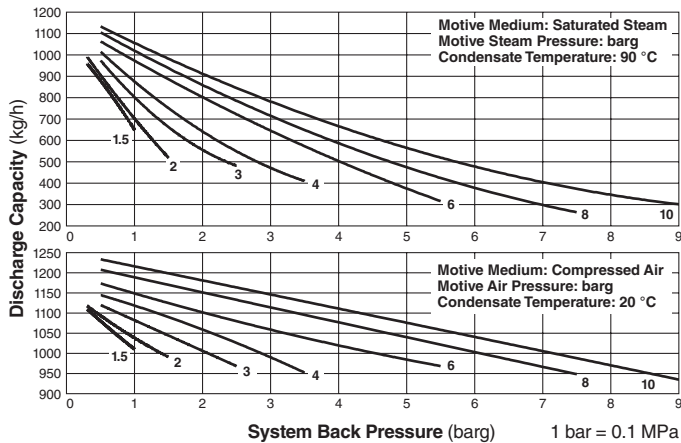

● **CORRECTION FACTOR**

For discharge capacity graph **C** with filling head other than 630 mm (minimum filling head: 300 mm)

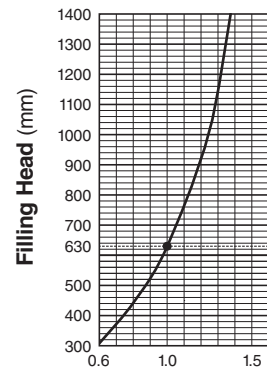

NOTE:

- A check valve must be installed at both the pumped medium inlet and outlet. To achieve the above capacities with the standard GP10L configuration, either TLV check valves CK3MG (inlet & outlet), or CKF5M (inlet) and CKF3M (outlet) must be used, depending on connection type.
- Motive medium pressure minus back pressure must be greater than 0.5 bar.
- In closed system applications, the motive medium must be compatible with the liquid being pumped. If a non-condensable gas such as air or nitrogen is used as the motive medium, consult TLV for assistance.
- A strainer must be installed at the motive medium and pumped medium inlets.

● **FILLING HEAD AND PRESSURES**

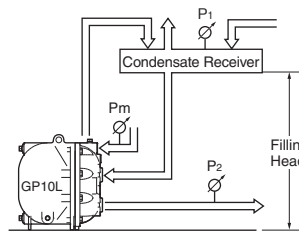

The discharge capacity is determined by the motive medium, motive medium pressure (P_m) and back pressure (P_2).

Make sure that:
Discharge Capacity × Correction Factor
> Required Flow Rate

Dimensions

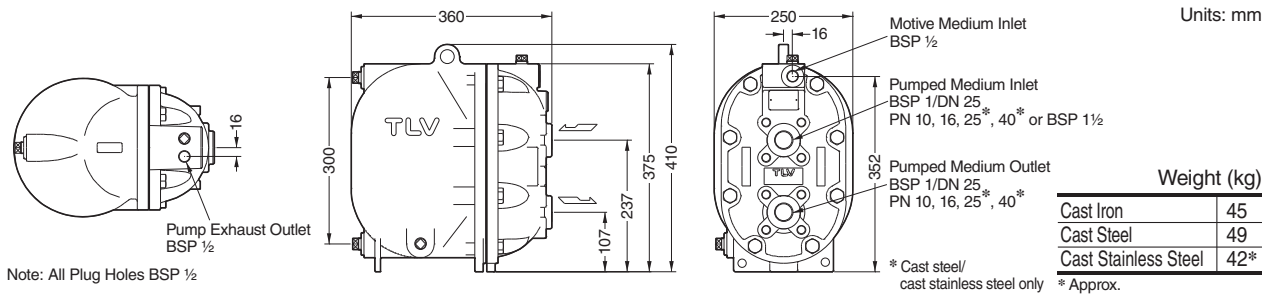

Size of Receiver/Reservoir

The receiver/reservoir must have a capacity sufficient to store the condensate produced during the PowerTrap operation and discharge. A receiver will generally be larger than a reservoir because it must handle the condensate both as a liquid and as flash steam, and separate one from the other so that only condensate is sent to the PowerTrap.

1. Size of Receiver (flash steam is involved) (Length: 1 m)

Flash steam up to (kg/h)	Receiver diameter (mm)	Vent pipe diameter (mm)
25	80	25
50	100	50
75	125	50
100	150	80
150	200	80
200	200	100
300	250	125
400	300	125
500	350	150
700	400	200
800	450	200
1000	500	200
1100	500	250
1400	550	250
1500	600	250

2. Size of Reservoir (flash steam is not involved)

Amount of condensate (kg/h)	Reservoir diameter (mm) and length (m)						
	40	50	80	100	150	200	250
300 or less	1.2m	0.7					
400	1.5	1.0					
500	2.0	1.2	0.5				
600		1.5	0.6				
800		2.0	0.8	0.5			
1000			1.0	0.7			
1500			1.5	1.0			
2000			2.0	1.3	0.6		
3000				2.0	0.9	0.5	
4000					1.2	0.7	
5000					1.4	0.8	0.5
6000					1.7	1.0	0.6
7000					2.0	1.2	0.7
8000						1.3	0.8
9000						1.5	0.9
10000						1.7	1.0

Reservoir length can be reduced by 50% when the motive medium pressure (Pm) divided by back pressure (P2) equals 2 or greater (when $P_m \div P_2 \geq 2$).

3. If flash steam is condensed before it enters the receiver/reservoir, compare tables 1 and 2 and choose the larger of the two sizes.

Steam or Air Consumption (Motive Medium)

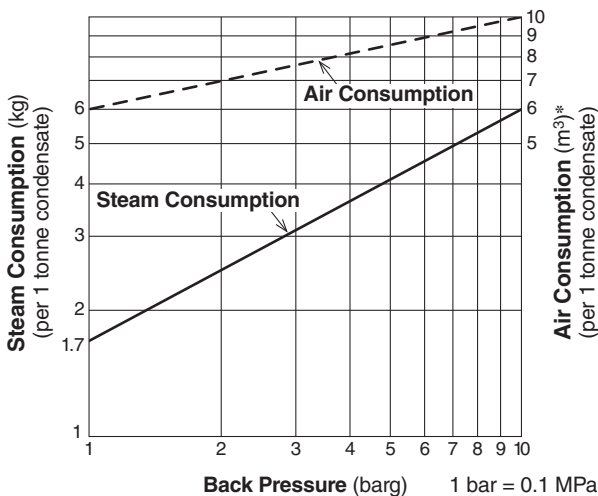

* Equivalent consumption of air at 20 °C under atmospheric pressure

Cycle Counter (option)

Two types of counter can be installed on the GP10L to monitor the number of pumping cycles and help to determine the timing of maintenance, or estimate the volume of pumped condensate.

- C1CM – (Counter Unit Type): Self-contained standalone unit. Includes an LCD counter display and an operation indicator LED
- C1SM – (Terminal Box Type): Designed for use with remote monitoring equipment and systems.

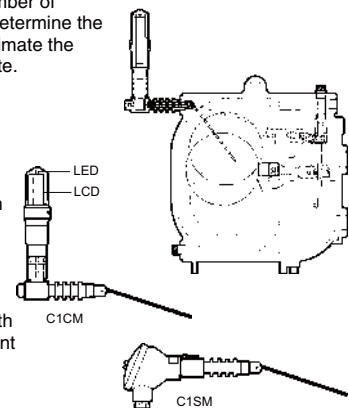

See the Cycle Counter SDS for further details.

System Package (Open Systems)

Single System Package Type S1L

Discharge Capacity: see discharge capacity graph **A** (no correction factor required, max. capacity 1 t/h)
 Maximum Allowable Flash Steam: 100 kg/h Tank Size: 12 ℓ Weight: 120 kg

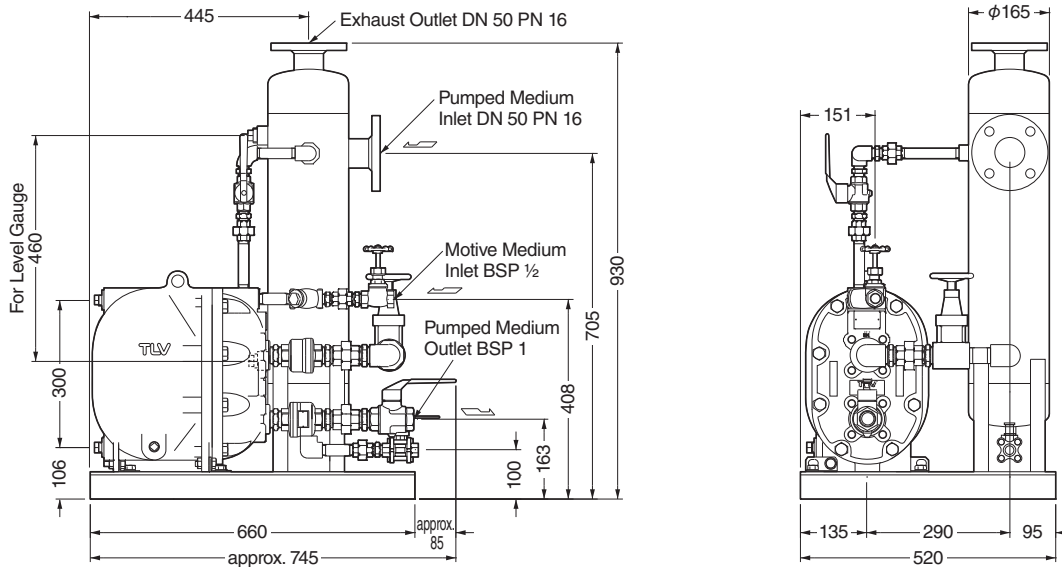

Single System Package Type S1M

Discharge Capacity: see discharge capacity graph **B** (no correction factor required, max. capacity 1.5 t/h)
 Maximum Allowable Flash Steam: 200 kg/h Tank Size: 22 ℓ Weight: 130 kg

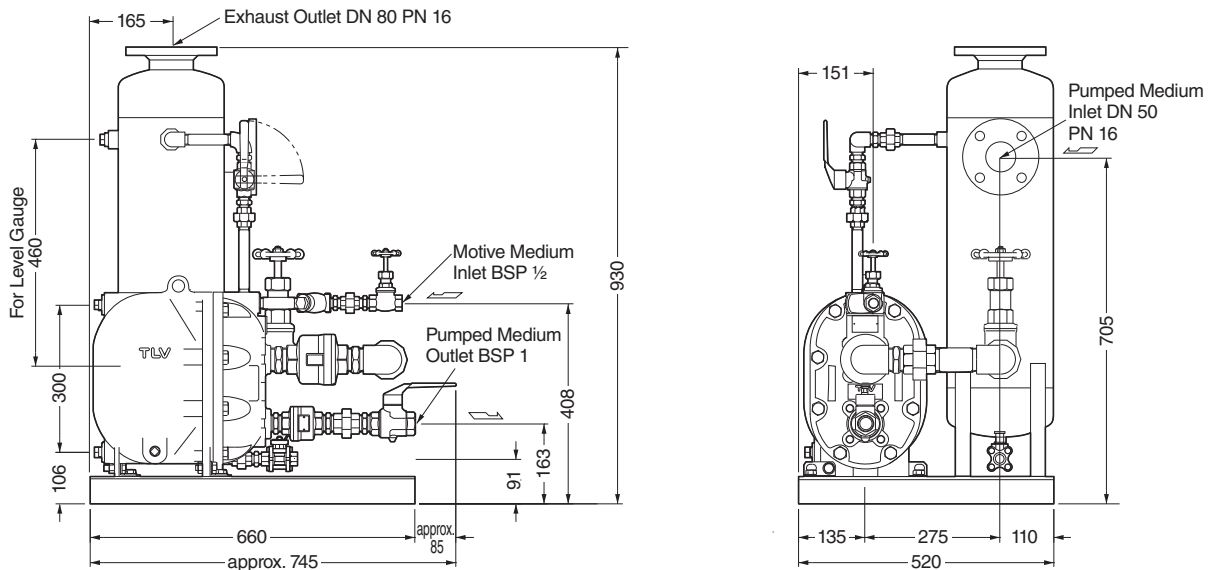

Standards:

Flanged connections: DIN 2501

Screwed connections: DIN 2999

Other standards available

Actual specifications may differ from the ones shown. Please consult TLV for details.

Units: mm