



EF200-C Stainless Steel Vortex Flowmeter

Features

High-performance vortex flowmeter with robust sensor for highly accurate volume or mass flow measurements of saturated and superheated steam, air and water.

1. DSC (Differential Switched Capacitance) sensor offers a wide measuring range, with a high resistance to thermal shock, vibration and water hammer.
2. Integrated pressure measuring unit enables mass flow calculation even for superheated steam at fluctuating pressures - all in one device. Optional for EF200F-C and EF200R-C.
3. Integrated flow computer calculates mass flow from measured volume flow and temperature variables.
4. Measures steam dryness fraction (80 to 100%) — Optional for EF200F-C. See page 3 for conditions.
5. Capable of simultaneous pulse (interval) and analog (instantaneous) output.
6. Requires no maintenance, has no moving parts, and experiences no zero point drift.
7. Low pressure drop through body.



Pressure Equipment Directive (PED)



This product fully conforms to the requirements of the Pressure Equipment Directive (PED, 2014/68/EU) and features CE marking where applicable.

Specifications

Meter Body/Sensor

Model	EF200W-C	EF200F-C	EF200R-C
Connection	Between Flanges (Flangeless, Full Bore)	Flanged (Full Bore)	Flanged (Reduced Bore)
Size (DN)	15, 25, 40, 50, 80, 100, 150	15, 25, 40, 50, 80, 100, 150, 200, 250, 300	25, 40, 50, 80, 100, 150, 200
Connection Compatibilities	See details in the Dimensions section		
Operating Press. Range (barg)	0 to 49.6 (See the graph to the right for details)		
Temperature Range (°C)	-200 ¹⁾ to +400 (See the graph to the right for details)		
Applicable Fluids ²⁾³⁾	Steam, Air, Water		
Accuracy ⁴⁾	Volume Flow	Steam / Air : ±1% of reading (Re>20000) : ±10% of reading (Re: 5000 to 20000) Water : ±0.75% of reading (Re>20000) : ±10% of reading (Re: 5000 to 20000)	Steam / Air : ±1% of reading (Re>10000) : ±5% of reading (Re: 5000 to 10000) Water : ±0.75% of reading (Re>10000) : ±5% of reading (Re: 5000 to 10000)
	Mass Flow	Saturated steam : ±2.0% of reading (Re>20000) : ±10% of reading (Re: 5000 to 20000)	Saturated steam : ±2.0% of reading (Re>10000) : ±5.7% of reading (Re: 5000 to 10000)
Repeatability	± 0.2% of reading		
Mounting Position	No restriction with regards to meter accuracy		
Accessories ⁵⁾	Centering rings, threaded bolts, nuts, washers and flange gaskets		

- ¹⁾ Subject to the limitations of fluid freezing point ²⁾ For superheated steam and air, an external pressure sensor and flow computer may be required if inlet pressure fluctuates
³⁾ Do not use for toxic, flammable or otherwise hazardous fluids
⁴⁾ Accuracy may be lower than indicated for wet saturated steam (steam mixed with condensate)
⁵⁾ For flangeless model EF200W-C only, to ensure concentric installation

Transmitter

Explosion Class	Non-explosion proof
Ambient Temperature	-40 to +80 °C
Protection Class	IP66 and IP67, NEMA 4X
Output	Output 1: Analog output 4 to 20 mA DC Output 2: Open collector pulse (Pulse, frequency, or switch output) Simultaneous output possible
Power Source	13 to 35 V DC (24 V DC recommended)
Power Consumption	Max. 2.77 VA
Power Line Connection	G ¹ / ₂
Field Wiring	2-wire System (2-conductor, shielded, 0.5 to 2.5 mm ²) (AWG 20 to 14)
Load Line Resistance	Maximum 500 Ω at 24 V
Accessories*	Connecting Cable (30 m)

Pressure/Temperature Operating Range

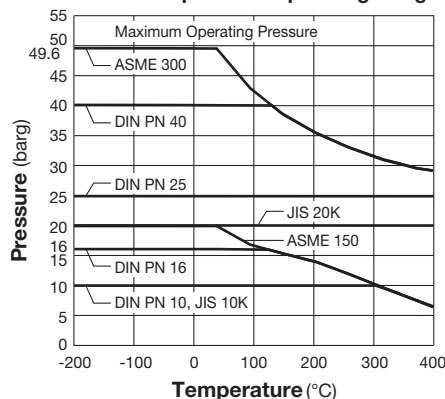

1 bar = 0.1 MPa

Reynolds Number (Re) Calculation:

$$Re = \frac{d \times V}{\nu}$$

d = pipe diameter V = velocity
ν = viscosity

Terminal Connection Method

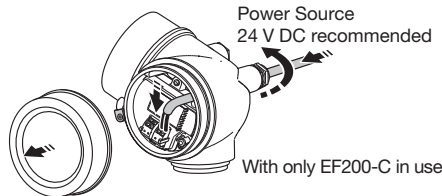

Display

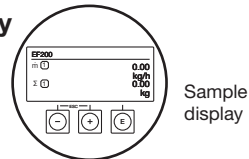

*Remote version only



To avoid abnormal operation, accidents or serious injury, DO NOT use this product outside of the specification range. Local regulations may restrict the use of this product to below the conditions quoted.

Specifications

No.	Description	Material	DIN EN	ASTM/AISI
①	Meter Body	Cast Stainless Steel	EN 1.4408*	A351 Gr. CF3M
②	Bluff Body	Cast Stainless Steel	EN 1.4408*	A351 Gr. CF3M
③	DSC Sensor	Stainless Steel	DIN/EN 1.4404	AISI316L*
④	Housing Support	Cast Stainless Steel	EN 1.4408*	A351 Gr. CF3M
⑤	Transmitter Housing	Die-cast Aluminium	—	—
⑥	Display	—	—	—
⑦	Nameplate	—	—	—

* Equivalent materials

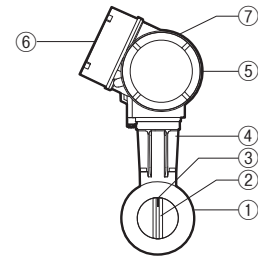

Piping Installation

Required Length of Straight Piping

Element	No Flow Conditioner	With Flow Conditioner* (Rectifier)
Control Valve		
Concentric Reducer (Convergent-Pipe)		
Concentric Diffuser (Expansion-Pipe)		
Eccentric Reducer (Convergent-Pipe)		
One 90 Elbow or T-piece		
Two 90 Elbows (2-Dimensional)		
Two 90 Elbows (3-Dimensional)		
Combination Pipe (Elbows & Eccentric Reducer, etc.)		

A = Upstream, B = Downstream, D = Nominal Diameter

* Cannot be used in conjunction with the Steam Dryness Fraction Calculator option

Note: •The installation positions shown are for steam and high temperature fluids
•Minimum required piping length shown. Use longer straight piping where possible.

Mounting Position

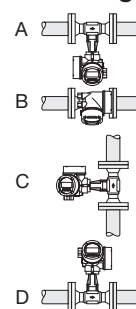

There is no restriction for mounting position (A – D) in regards to meter accuracy. However, special care is recommended for the following flow mediums:

1. High-temperature Fluids

For high-temperature fluids (steam, condensate), positions A, B or C should be selected to protect the transmitter from heat.

2. Water

To make sure the pipes are completely flooded with water, position C is recommended.

Pressure Measurement Points

If a pressure measuring point is installed after the device, ensure that there is a large enough distance between the device and the measuring point so that there are no negative effects on vortex formation in the sensor.

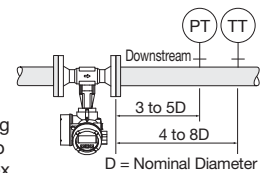

Pipeline Insulation

The pipe stand serves as a radiator and protects the electronics from overheating.

Therefore, ensure that sufficient surface area remains exposed. Be sure not to insulate past the level marked "max." on the pipe stand.

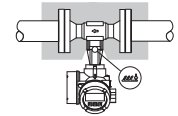

Ensuring Steam Quality

Wet steam has a higher density than saturated steam. Since the flowmeter mass flow calculations are based on saturated steam density, the actual mass flow of wet steam will be higher than shown by the flowmeter. The upstream installation of a separator (DC3S) is suggested to ensure steam quality and flowmeter accuracy. The proper separation and drainage of condensate is a recommended practice for all steam applications.

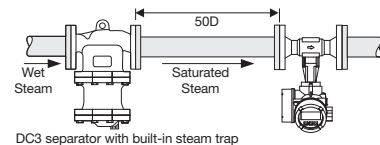

Options

Steam Dryness Fraction Calculator	Enables the measurement of steam dryness fraction of saturated steam between 80 to 100%. This option applies only for Model EF200F-C (DN 25 to DN 300) and must also satisfy other conditions. See below for further restrictions.
Overvoltage Protection	Protects the circuit from lightning
Flow Conditioner	Compatible with PN 10/16, 25/40, ASME Class 150, 300, and JIS 10K/20K flange standards and other optional standards (including flangeless).
Pipe Mounting Kit for Remote Transmitter	Suitable for pipes with 20 to 70 mm outer diameter. (Includes bracket, threaded bolts and nuts.)
Sunshade for Transmitter	Protects the transmitter from temperature rises due to direct sunlight when installed in an external location.
Pressure measuring unit (EF200F-C, EF200R-C)	Integrated pressure measurement sensor. Pressure compensation is possible with just the flowmeter. * See "Pressure Measuring Unit Details"

● Pressure Measuring Unit Details

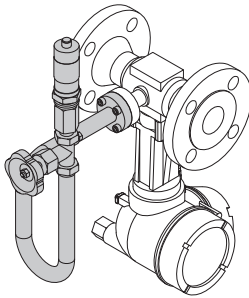

Connection	Connect to the dedicated flange provided on the flowmeter body. The mounting direction can be changed in 90° increments.
Component parts	Pressure measuring cell, siphon, shutoff valve, cable
Material	Stainless steel

1. The pressure measuring unit is available as an option for EF200F-C only. It cannot be fitted to non-compatible flowmeters, nor retroactively fitted to the standard EF200F-C.
2. Do not remove the siphon tube as it is essential for steam pressure measurement.

Conditions for optional "Steam Dryness Fraction Calculator"

Steam Dryness Fraction

The ratio of steam by mass in wet saturated steam

$$\text{Steam Dryness Fraction (\%)} = \frac{\text{Steam mass flow rate}}{(\text{Steam mass flow rate}) + \text{Water mass flow rate}} \times 100$$

This function can be used only for the following models and under the following conditions.

Model	Size (DN)	Flow velocity (m/s)	Temp. Range (°C)	Press. Range (barg)
EF200F-C	25, 40, 50, 80, 100, 150, 200, 250, 300	$5 \leq u \leq 50$	$82 < T < 320$	$-0.5 < P < 98.9$

Flow Rates

Refer to the EF200F-C table on page 4 for the measurable flow rates.

Mounting Position

Meter body must be installed in the downward position.

Operating Conditions

Use at a stable pressure and flow rate.

Measurable Dryness Range

80 to 100%

(When used with superheated steam, steam dryness fraction will be displayed as 100%, the maximum possible reading)

Accuracy for wetted steam

Mass Flow: $\pm 4\%$ of reading

Dryness: See graph to the right.

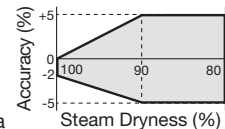

Flow Conditioner

Cannot be used in conjunction with a flow conditioner. Ensure the required length straight piping upstream.

External Output

Steam dryness fraction output is analog. A flow computer and an additional compensation signal (for pressure or temperature) are required to display the instantaneous mass flow rate.

Flow Rate for Saturated Steam

● EF200W-C Flangeless

(Unit: kg/h)

Size (DN)	15		25		40		50		80		100		150		Temp (°C)
	Min.	Max.	Min.	Max.	Min.	Max.	Min.	Max.	Min.	Max.	Min.	Max.	Min.	Max.	
0.5	4.4	30	13	140	28	325	46	527	102	1187	166	1930	389	4531	111.6
1	5	40	14	183	32	424	52	689	117	1551	190	2521	445	5919	120.4
2	6	58	17	267	39	620	63	1006	141	2263	229	3678	537	8636	133.7
3	6.9	76	20	350	45	811	72	1316	161	2962	262	4814	614	11303	143.7
4	7.6	94	22	432	49	1000	80	1623	179	3652	291	5936	682	13936	151.9
5	8.3	112	24	512	54	1187	87	1927	195	4336	317	7047	743	16545	158.9
6	8.9	130	25	593	58	1373	94	2229	210	5015	341	8150	799	19136	165
7	9.5	147	27	673	62	1558	100	2529	224	5691	363	9249	851	21714	170.5
8	10	165	28	752	65	1743	105	2828	236	6364	383	10342	900	24282	175.4
9	11	182	30	832	68	1927	111	3126	248	7035	403	11433	947	26843	179.9
10	11	199	31	911	72	2110	116	3424	260	7705	423	12522	991	29399	184.1
12	12	234	34	1069	78	2476	125	4018	282	9042	457	14694	1073	34500	191.6
15	14	286	37	1306	86	3025	139	4909	311	11046	506	17951	1186	42144	201.4
20	15	373	42	1702	98	3942	158	6397	355	14394	577	23391	1354	54918	214.9
25	17	461	47	2102	108	4867	175	7897	394	17768	640	28876	1504	67791	226.1
30	18	549	51	2505	118	5802	191	9413	430	21180	700	34420	1642	80810	235.7

1 bar = 0.1 MPa

● EF200F-C Flanged

(Unit: kg/h)

Size (DN)	15		25		40		50		80		100		150		200		250		300		Temp (°C)
	Min.	Max.	Min.	Max.	Min.	Max.	Min.	Max.	Min.	Max.	Min.	Max.	Min.	Max.	Min.	Max.	Min.	Max.	Min.	Max.	
0.5	3.1	21	10	108	23	267	39	446	86	1001	149	1735	339	3947	594	6919	933	10870	1321	15392	111.6
1	3.5	27	11	142	27	349	44	583	99	1308	171	2266	388	5156	679	9038	1066	14201	1510	20107	120.4
2	4.3	40	13	207	32	510	53	850	119	1909	206	3307	468	7523	820	13188	1288	20723	1823	29336	133.7
3	4.9	53	15	271	37	667	61	1113	136	2498	236	4328	535	9846	938	17260	1474	27120	2086	38397	143.7
4	5.4	65	17	334	41	823	68	1372	151	3080	262	5336	594	12140	1041	21280	1636	33438	2316	47337	151.9
5	5.9	78	18	397	44	977	74	1629	165	3657	285	6335	648	14412	1135	25264	1783	39694	2524	56199	158.9
6	6.3	90	20	459	48	1130	79	1885	177	4230	306	7328	696	16669	1220	29220	1917	45911	2714	65000	165
7	6.7	102	21	521	51	1282	84	2139	189	4800	326	8315	742	18915	1300	33157	2042	52096	2891	73757	170.5
8	7.1	114	22	583	54	1434	89	2392	199	5368	345	9298	784	21152	1375	37078	2159	58257	3057	82480	175.4
9	7.5	126	23	645	56	1585	94	2644	210	5934	363	10279	825	23383	1445	40986	2270	64401	3214	91178	179.9
10	7.8	138	24	706	59	1736	98	2896	219	6499	380	11257	863	25609	1512	44890	2376	70532	3364	99858	184.1
12	8.5	163	26	829	64	2038	106	3398	238	7626	411	13211	935	30053	1638	52685	2574	82770	3644	117184	191.6
15	9.4	199	29	1012	71	2489	117	4151	263	9316	454	16138	1033	36712	1811	64355	2845	101109	4027	143149	201.4
20	11	259	33	1319	80	3244	134	5410	300	12140	519	21030	1179	47840	2067	83860	3247	131756	4597	186538	214.9
25	12	320	36	1629	89	4005	148	6678	332	14986	576	25960	1310	59054	2296	103520	3608	162642	5108	230266	226.1
30	13	382	39	1942	97	4774	162	7961	363	17864	629	30945	1430	70394	2507	123400	3939	193875	5577	274485	235.7

1 bar = 0.1 MPa

● EF200F-C Flanged (when used with the optional Steam Dryness Fraction Calculator)

(Unit: kg/h)

Size (DN)	25		40		50		80		100		150		200		250		300		Temp (°C)
	Min.	Max.	Min.	Max.	Min.	Max.	Min.	Max.	Min.	Max.	Min.	Max.	Min.	Max.	Min.	Max.	Min.	Max.	
0.5	10	72	23	178	39	297	86	667	149	1156	339	2631	594	4612	933	7247	1321	10261	111.6
1	11	94	27	233	44	388	99	872	171	1511	388	3437	679	6025	1066	9467	1510	13403	120.4
2	14	138	35	340	57	567	128	1272	221	2204	502	5015	880	8792	1382	13814	1956	19558	133.7
3	19	181	45	445	75	743	167	1666	289	2885	657	6564	1151	11506	1809	18080	2560	25597	143.7
4	23	223	55	548	92	915	206	2054	356	3557	810	8093	1419	14187	2230	22291	3156	31559	151.9
5	27	265	66	651	109	1086	244	2438	423	4223	961	9608	1685	16843	2647	26464	3747	37467	158.9
6	31	306	76	753	126	1256	282	2820	489	4885	1112	11113	1949	19481	3061	30609	4334	43335	165
7	35	347	86	855	143	1436	320	3200	555	5543	1262	12610	2211	22105	3474	34732	4918	49174	170.5
8	39	389	96	956	160	1594	358	3578	620	6199	1411	14101	2472	24719	3885	38840	5499	54989	175.4
9	44	430	106	1057	177	1763	396	3956	686	6852	1559	15588	2733	27326	4294	42936	6079	60788	179.9
10	48	471	116	1157	194	1930	434	4332	751	7505	1708	17073	2993	29928	4703	47023	6658	66575	184.1
12	56	552	136	1356	227	2265	509	5084	881	8807	2004	20035	3513	35121	5519	55183	7813	78127	191.6
15	68	675	166	1659	277	2767	622	6211	1076	10758	2448	24474	4291	42902	6742	67410	9544	95438	201.4
20	88	879	217	2163	361	3606	810	8093	1403	14020	3190	31893	5591	55907	8785	87842	12437	124366	214.9
25	109	1086	268	2670	446	4452	1000	9990	1731	17306	3937	39369	6902	69012	10844	108434	12353	123520	226.1
30	130	1294	319	3182	531	5306	1191	11909	2064	20630	4693	46929	8227	82265	12926	129257	18301	183001	235.7

1. Please contact TLV for a flow rate other than shown above.

1 bar = 0.1 MPa

Flow Rate for Saturated Steam

● EF200R-C Flanged (Reduced Bore)

(Unit: kg/h)

Size (DN)	25		40		50		80		100		150		200		Temp (°C)
	Min.	Max.	Min.	Max.	Min.	Max.	Min.	Max.	Min.	Max.	Min.	Max.	Min.	Max.	
0.5	3.1	21	10	108	23	267	39	446	86	1001	149	1735	339	3947	111.6
1	3.5	27	11	142	27	349	44	583	99	1308	171	2266	388	5156	120.4
2	4.3	40	13	207	32	510	53	850	119	1909	206	3307	468	7523	133.7
3	4.9	53	15	271	37	667	61	1113	136	2498	236	4328	535	9847	143.7
4	5.4	65	17	334	41	823	68	1372	151	3080	262	5336	594	12140	151.9
5	5.9	78	18	397	44	977	74	1630	165	3657	285	6335	648	14413	158.9
6	6.3	90	20	459	48	1130	79	1885	177	4230	306	7327	696	16669	165
7	6.7	102	21	521	51	1282	84	2139	189	4800	326	8315	742	18915	170.5
8	7.1	114	22	583	54	1434	89	2392	199	5368	345	9298	784	21150	175.4
9	7.5	126	23	645	56	1585	94	2644	210	5934	363	10279	825	23382	179.9
10	7.8	138	24	706	59	1736	98	2896	219	6499	380	11257	863	25610	184.1
12	8.5	163	26	829	64	2038	106	3398	238	7626	411	13211	935	30051	191.6
15	9.4	199	29	1012	71	2489	117	4151	263	9316	454	16138	1033	36710	201.4
20	11	259	33	1319	80	3244	134	5410	300	12140	519	21030	1179	47837	214.9
25	12	320	36	1629	89	4005	148	6678	332	14986	576	25960	1310	59052	226.1
30	13	382	39	1942	97	4774	162	7961	363	17864	629	30945	1430	70390	235.7

1 bar = 0.1 MPa

Flow Rate for Air and Water

(Unit: m³/h)

Model	EF200W-C				EF200F-C				EF200R-C			
	Air (0 °C, Atm. Press.)		Water (20 °C)		Air (0 °C, Atm. Press.)		Water (20 °C)		Air (0 °C, Atm. Press.)		Water (20 °C)	
Size (DN)	Min.	Max.	Min.	Max.	Min.	Max.	Min.	Max.	Min.	Max.	Min.	Max.
15	4.1	35	0.23	7	2.9	25	0.2	4.9	—	—	—	—
25	11	162	0.41	19	8.8	125	0.35	15	2.9	25	0.20	4.9
40	26	374	0.95	45	22	308	0.78	36	8.8	125	0.34	15
50	43	606	1.54	73	36	513	1.3	61	22	308	0.78	37
80	96	1365	3.46	164	81	1151	2.92	138	36	513	1.30	62
100	164	2326	5.90	279	140	1995	5.05	239	81	1151	2.92	138
150	367	5210	13.20	625	319	4538	11.49	544	140	1995	5.05	239
200	—	—	—	—	560	7955	20.15	954	319	4538	11.49	544
250	—	—	—	—	880	12500	31.65	1500	—	—	—	—
300	—	—	—	—	1246	17700	44.82	2123	—	—	—	—

Dimensions

● EF200W-C Flangeless

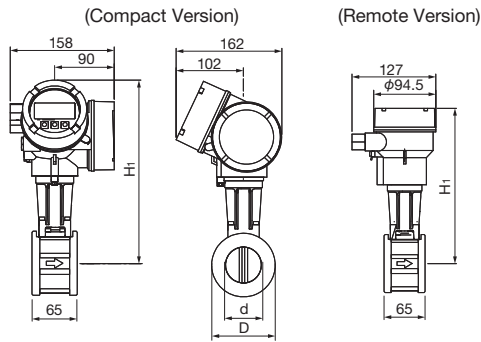

EF200W-C Flangeless* (mm)

DN	φD	φd	H ₁		Weight** (kg)
			Compact	Remote	
15	45	16.5	252.5	222.8	3
25	64	27.6	262	232.3	
40	82	42	270.5	240.8	
50	92	53.5	277.5	247.8	4
80	127	80.3	291.5	261.8	
100	157.2	102.3	304	274.3	7
150	215.9	156.8	330	300.3	9

* Compatible with DIN EN 1092-2, PN10/16, 25/40, ASME Class 150, 300, and JIS 10K/20K flange standards

** Weight is for compact version.

● EF200F-C/EF200R-C Flanged

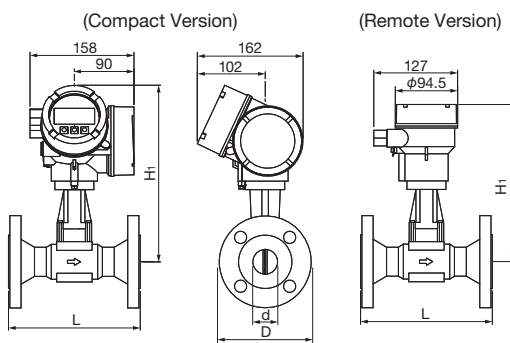

EF200F-C Flanged (mm)

DN	L					φd	H ₁		Weight* (kg)
	DIN EN 1092-1			ASME Class			Compact	Remote	
	PN16	PN25	PN40	150RF	300RF				
15	—	—	—	—	—	13.9	252	225	5
25	—	—	—	—	—	24.3	258	231	7
40	—	—	200	200	200	38.1	266	239	9
50	—	—	—	—	—	49.2	272	245	11
80	—	—	—	—	—	73.7	286	259	16
100	250	—	250	250	250	97	300	273	21
150	300	—	300	300	300	146.3	325	298	37
200	251	287	303	247	285	193.7	348	321	72
250	286	322	356	280	324	242.8	375	348	111
300	348	376	422	334	386	288.9	394	370	158

Other standards available, but weight may vary.

* Weight is for compact version, PN 40 flanges.

● EF200W-C/EF200F-C/EF200R-C

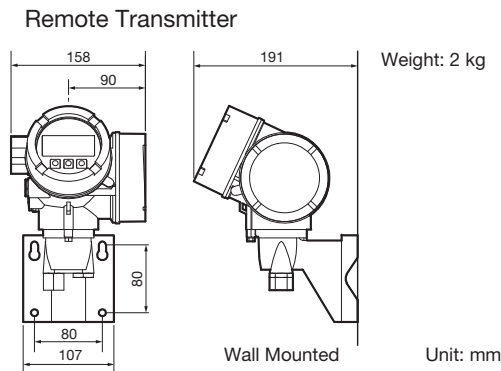

EF200R-C Flanged (Reduced Bore) (mm)

DN	L					φd	H ₁		Weight* (kg)
	DIN EN 1092-1			ASME Class			Compact	Remote	
	PN16	PN25	PN40	150RF	300RF				
25	—	—	—	—	—	22.1	252	225	6
40	—	—	200	200	200	30	258	231	10
50	—	—	—	—	—	45	266	239	12
80	—	—	—	—	—	56.5	272	245	16
100	250	—	250	250	250	87	286	259	23
150	300	—	300	300	300	112	300	273	42
200	—	300	—	—	—	146.3	325	298	63

Other standards available, but weight may vary.

* Weight is for compact version, PN 40 flanges.