

Art84M

PN20 Brass Swing Check Valve (Brass Seat)



Technical data

Max pressure: 20 Bar

Working temp: 0°C to +150°C

Features

- Screwed BSP Parallel (ISO 228/1)
- Brass body
- Metal seat

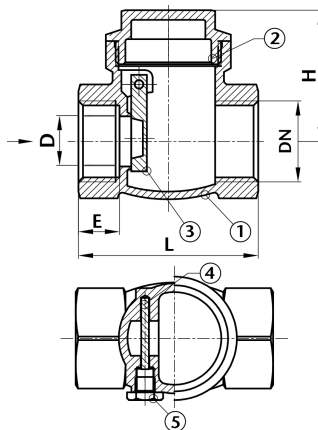

DN	1/2"	3/4"	1"	1 1/4"	1 1/2"	2"	2 1/2"	3"	4"
L	46	56	63.5	67.5	82	94	105	126.5	159
H	34	37.5	44.5	50	56.5	65.5	77	82	103
E	10.5	13.5	14.5	14	17	19	21	23.5	27.5
D	13	18	22	29	33	42.5	50	62	83
Kv	6.4	10.0	16.9	30.5	43.0	60.0	68.0	82.0	121.0
Kgs	0.15	0.22	0.34	0.54	0.74	1.13	1.83	2.53	5.05

N.	Part Name	Materials
1	Body	Brass CW617N
2	Bonnet	Brass CW617N
3	Disc	Brass CW617N
4	Pin	Stainless Steel 304
5	Plug	Brass CW617N

