



Art675

DZR Brass Pressure Reducing Valve w/ Gauge (Compression Fit)



Technical data

Max inlet pressure (static):	16 Bar
Adjustable pressure range:	1 - 6 Bar
Pressure gauge:	0 - 10 Bar
Min inlet pressure:	1 Bar
Max inlet temperature:	80°C
Factory set pressure:	3 Bar

DN	15mm	22mm
L	123	104
B	92.5	92.5
C	52.5	52.5
D	1/4"	1/4"
Kgs	0.61	0.54

N.	Part Name	Materials
1	Olives	Copper -T2
2	Nuts	DZR - CW602N
3	Body	DZR - CW602N
4	Cartridge	Brass - CW617N
5	Plastic Cap	Nylon
6	Spring	Spring Steel
7	Screw	Brass - Hpb58-3
8	Nut	Brass - Hpb58-3
9	Plug	Nylon
10	O-Ring	EPDM
11	Gauge	Steel - Q235A
12	Reducer	DZR - CW602N
13	Pre-set Label	

Features

- 22mm with 15mm adaptors (adaptors supplied loose)
- Conforms to BS EN 1567
- Supplied with a loose pressure gauge
- Compression ends (BS EN1254-2)

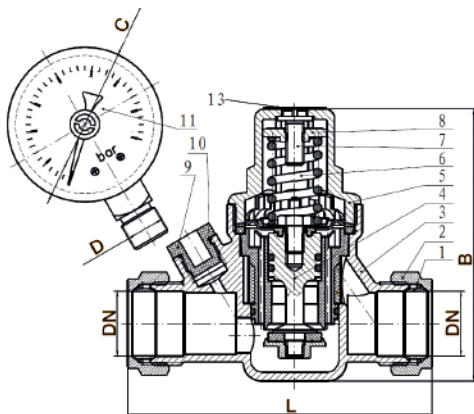

15mm Adaptor

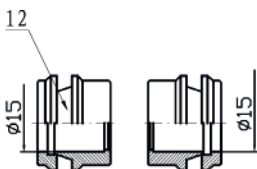

Cavitation Chart

