



Art640HW

PN20 DZR Brass Gate Valve (Handwheel Operated)



Features

- Screwed BSP Taper (ISO 7/1) or NPT (ANSI B1.20.1)
- DZR brass body & wedge
- Cast hand wheel
- BS5154

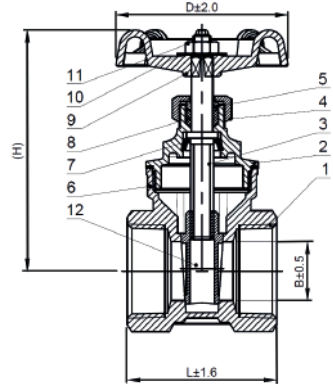

Technical data

Max pressure: 20 Bar

Working temp: -20°C to +170°C

DN	1/2"	3/4"	1"	1 1/4"	1 1/2"	2"
L	43	46	52	65	66	82.5
H	69.7	75	84.5	99	109.5	130.5
D	53	53	60	72	72	80
B	13	17	21	27	34	45
Kv	8.4	15.2	22.1	39.8	63.1	142.0
Kgs	0.25	0.33	0.45	0.71	0.93	1.44

N.	Part Name	Materials
1	Body	DZR CW602N
2	Bonnet	DZR CW602N
3	Stem	DZR CW602N
4	Packing Nut	Brass HPb58-2
5	Washer Ring	Brass HPb58-2
6	Gasket	PTFE
7	Lock Ring	Brass HPb58-2
8	Stem Packing	PTFE
9	Hand wheel	Cast Iron HT200
10	Nameplate	Steel L2
11	Hex Nut	Steel Q235A
12	Disc	DZR CW602N

