



Art299 Brass Binder Test Points



Features

- Male BSP Taper
- Self Sealing pressure / temperature binder test point

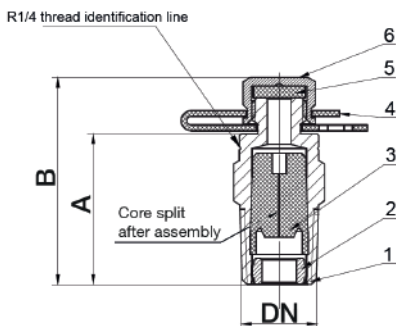

Technical data

Max pressure: 35 Bar

Working temp: -10°C to +135°C

DN	1/4"	1/2"
A	32.27	36.14
B	35.77	39.64

N.	Part Name	Materials
1	Body	1/4" DZR Brass CW602N 1/2" Brass CW617N
2	Retaining Ring	DZR Brass CW602N
3	Rubber Plug	EPDM
4	Strap	PU
5	Rubber Ring	EPDM
6	Cap	DZR Brass CW602N

The test point is designed for use with 'needle' type push-in probes.

The body of the test point houses a self-sealing elastomeric core which minimises leakage when the test probe is withdrawn.

The cap contains a sealing washer to prevent the ingress of debris into the test point and to provide an extra seal against any possible seepage.

A coloured plastic strap retains the cap when pressure measurements are being taken. This is an important feature when installed in ceiling voids, for example, avoiding the cap being lost. The RED and BLUE straps are a visual indicator to show which is the upstream (+ RED) and the downstream (- BLUE) pressure points, important when connecting a manometer or other differential pressure measurement device.

Note: It is advisable to apply silicone oil or grease to the probe prior to insertion to avoid causing damage to the elastomer core.

Safety Note: Test point maximum recommended temperature: +135°C.

We do not suggest this product is used on water applications above boiling point as the sudden venting of the system to atmospheric pressure can be extremely dangerous.