

ART 368

PN20 Bronze 'Y' Type Strainer



Features

- Available in Screwed BSP Taper (ISO 7/1) or NPT (ANSI B1.20.1)
- Screwed cap

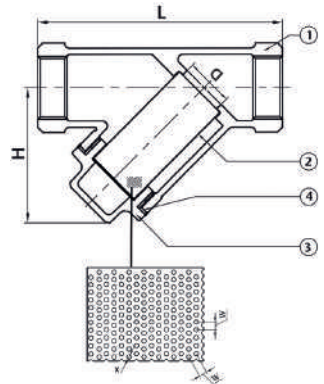

Technical data

Max pressure: 20 Bar

Working temp: -10°C to +232°C

DN	15	22	25	32	40	50
L	80.0	100.0	115.0	135.0	160.0	190.0
H	48.5	58.0	70.0	80.0	93.0	112.0
D	14.0	19.0	25.0	31.8	38.1	50.0
X	0.93	0.93	0.93	0.93	0.93	0.93
W	1.27	1.27	1.27	1.27	1.27	1.27
Kv	2.9	5.4	8.3	15.8	21.7	37.5
Kgs	0.31	0.49	0.71	0.99	1.46	2.44

N. Part Name Materials

1	Body	Bronze ASTM B62 C83600
2	Screen	Stainless Steel 304
3	Cap	Bronze ASTM B62 C83600
4	Gasket	Aramid fibres with binders

