

Large Diameter Couplings OD355.6 - 816

Specifications

L= Distance back from end of pipe that must be rounded, meet tolerances, and free from any wrapping to ensure correct assembly.

Coupling Type	Coupling Section Type	Sleeve Length S (mm)	Dimensions (mm)		Setting Gap X (mm)		Bolt Details		
			Distance L	Overall C	Min.	Max.	Bolt Dia.	Length (mm)	Torque (Nm)
Standard Sleeve	L02	150	150	243	25	50	M12	235	55 - 65
Long Sleeve	L03	250	200	348	25	150	M12	340	55 - 65
Standard Sleeve	YF2	178	150	276	38	76	M16	265	95 - 120
Long Sleeve	YF3	250	200	351	38	150	M16	340	95 - 120
Standard Sleeve	A2E	178	150	276	38	76	M16	265	95 - 120
Long Sleeve	A2H	254	200	351	38	150	M16	340	95 - 120
Standard Sleeve	XSG	254	200	411	57	117	M16	400	95 - 120

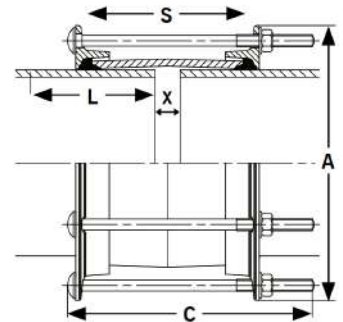

Pressure Working pressure is as shown in the table.
Site test pressure is 1.5x working pressure.

End Restraint Dedicated couplings DO NOT resist end load due to the internal pressure - adequate external restraint must be provided to prevent pipe pull out from the coupling.

Pipe OD (mm)	Pipe Material	Working Pressure (bar)	Gasket Mould No.	Tolerance (mm) on Pipe OD for Distance L (mm)		Coupling Section Type		Bolts No. x Dia	Weight (kg)		Diameter A (mm)
				+	-	Standard Sleeve	Long Sleeve		Standard Sleeve	Long Sleeve	
355.6	Steel & uPVC	23.2	J51LS	1.6	1.6	L02	L03	6 x M12	19.6	26.3	447
355.6	Steel	31.0	J51LS	1.6	1.6	L02	L03	8 x M12	20.0	26.9	447
358.6	Coated Steel	19.6	J51LS	1.6	1.6	L02	L03	6 x M12	19.7	26.5	450
358.6	Coated Steel	30.7	J51LS	1.6	1.6	L02	L03	8 x M12	20.2	27.1	450
378	Ductile Iron	29.2	J52LS	2.7	3.5	L02	L03	8 x M12	21.1	28.4	469
406.4	Steel & uPVC	27.2	J53LS	1.6	1.6	L02	L03	8 x M12	22.4	30.2	497
408.4	Coated Steel	27.0	J53LS	1.6	1.6	L02	L03	8 x M12	22.5	30.4	499
409.6	Coated Steel	27.0	J53LS	1.6	1.6	L02	L03	8 x M12	22.6	30.4	500
429	Ductile Iron	25.8	J54LS	2.8	4.0	L02	L03	8 x M12	23.6	31.7	520
457	Steel & uPVC	24.2	J55LS	1.6	1.6	L02	L03	8 x M12	24.9	33.5	548
460	Coated Steel	24.1	J55LS	1.6	1.6	L02	L03	8 x M12	25.0	33.7	551
480	Ductile Iron	23.1	J56LS	2.9	4.0	L02	L03	8 x M12	26.0	35.1	571
480	Ductile Iron	28.9	J56LS	2.9	4.0	L02	L03	10 x M12	26.5	35.7	571
508	Steel & uPVC	27.4	J57LS	1.6	1.6	L02	L03	10 x M12	27.8	37.4	598
511	Coated Steel	27.2	J57LS	1.6	1.6	L02	L03	10 x M12	27.9	37.6	602
532	Ductile Iron	26.1	J58LS	3.0	4.0	L02	L03	10 x M12	29.0	39.1	624
559	Steel & uPVC	24.9	J59LS	1.6	1.6	L02	L03	10 x M12	30.2	40.7	649
610	Steel & uPVC	22.9	J60LS	1.6	1.6	L02	L03	10 x M12	32.7	44.1	701
610	Steel	26.3	J60LS	1.6	1.6	L02	L03	12 x M12	33.1	44.6	701
613	Coated Steel	22.8	J60LS	1.6	1.6	L02	L03	10 x M12	32.8	44.3	704
613	Coated Steel	26.2	J60LS	1.6	1.6	L02	L03	12 x M12	33.2	44.8	704
635	Ductile Iron	22.0	J61LS	3.2	4.5	L02	L03	10 x M12	33.9	45.8	726
635	Ductile Iron	25.2	J61LS	3.2	4.5	L02	L03	12 x M12	34.3	46.3	726
660	Steel	24.3	J61LS	1.6	1.6	L02	L03	12 x M12	35.5	47.9	751
660	Steel	31.5	J61LS	1.6	1.6	YF2	YF3	10 x M16	62.6	74.5	770
663	Coated Steel	24.3	J61LS	1.6	1.6	L02	L03	12 x M12	35.7	48.1	754
663	Coated Steel	31.4	J61LS	1.6	1.6	YF2	YF3	10 x M16	62.9	74.8	773
711	Steel	22.6	J63LS	1.6	1.6	L02	L03	12 x M12	38.1	51.3	802
714	Coated Steel	22.4	J63LS	1.6	1.6	L02	L03	12 x M12	38.1	51.5	805
738	Ductile Iron	21.7	J63LS	3.4	4.5	L02	L03	12 x M12	39.3	53.1	830
738	Ductile Iron	28.2	J63LS	3.4	4.5	YF2	YF3	10 x M16	69.3	82.4	849
762	Steel	21.0	J64LS	1.6	1.6	L02	L03	12 x M12	40.4	54.6	852
762	Steel	27.3	J64LS	1.6	1.6	YF2	YF3	10 x M16	71.2	84.6	871
765	Coated Steel	21.0	J64LS	1.6	1.6	L02	L03	12 x M12	40.6	54.8	856
765	Coated Steel	27.2	J64LS	1.6	1.6	YF2	YF3	10 x M16	71.5	85.0	875
813	Steel	19.8	J65LS	1.6	1.6	L02	L03	14 x M12	43.3	58.5	903
816	Coated Steel	19.7	J65LS	1.6	1.6	L02	L03	14 x M12	43.3	58.7	906

Materials & Relevant Standards

Centre Sleeve/End Rings

Steel to BS EN10025-2: Grade S275JR

Bolts/Nuts/Washers

Bolts - Steel to BS EN ISO898-1: Property Class 4.8

Nuts - Steel to BS4190: Grade 4

Washers - Stainless Steel to BS1449:Part 2: Grade 304S15

Coatings

Body, Flange & End Ring - Rilsan Nylon 11 to WIS 4-52-01 Part 1

Nuts and Bolts - Sheraplex coated to WIS 4-52-03

Gaskets: L02/L03/YF2/YF3

Rubber 80 IRHD Moulded Compound to BS EN681-1:

Type WA,WC,WG or BS EN682: Type G
(other materials available on request)

Gaskets: A2E/A2H/XSXC

Rubber 70 IRHD Moulded Compound to BS EN681-1: Type WA, WC, WG
or BS EN682: Type G (other materials available on request)